

SCHEMATIC DIAGRAM (SV-2189H)

A
B
C
D
E
F
G
H

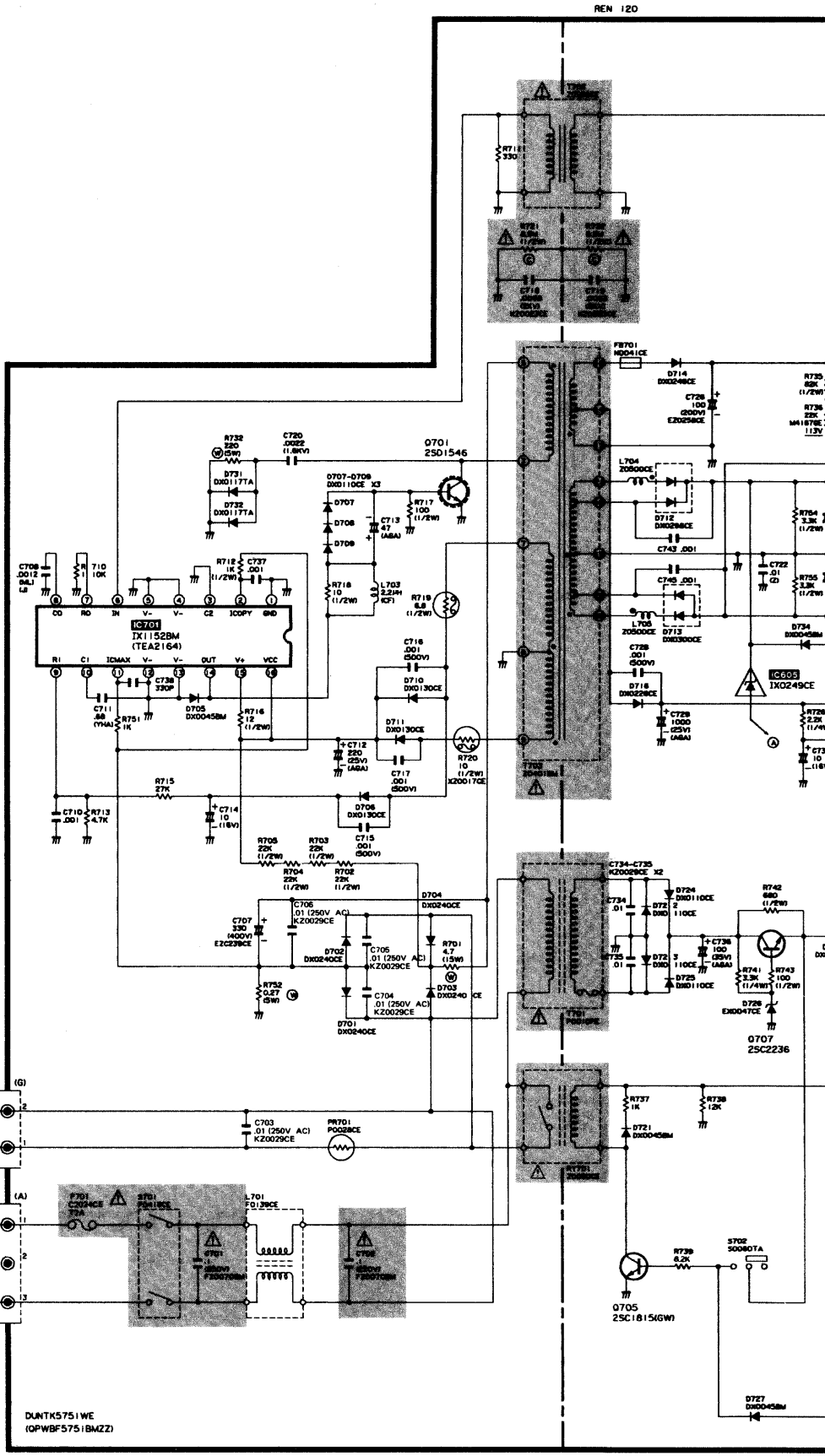

SERVICE PRECAUTION:

The area enclosed by this line (— — —) is directly connected with AC Mains Voltage. When servicing the area, connect an isolating transformer between TV receiver and AC line to eliminate hazard of electric shock.

DANTK5751 WE
(OPWBF5751BMZZ)

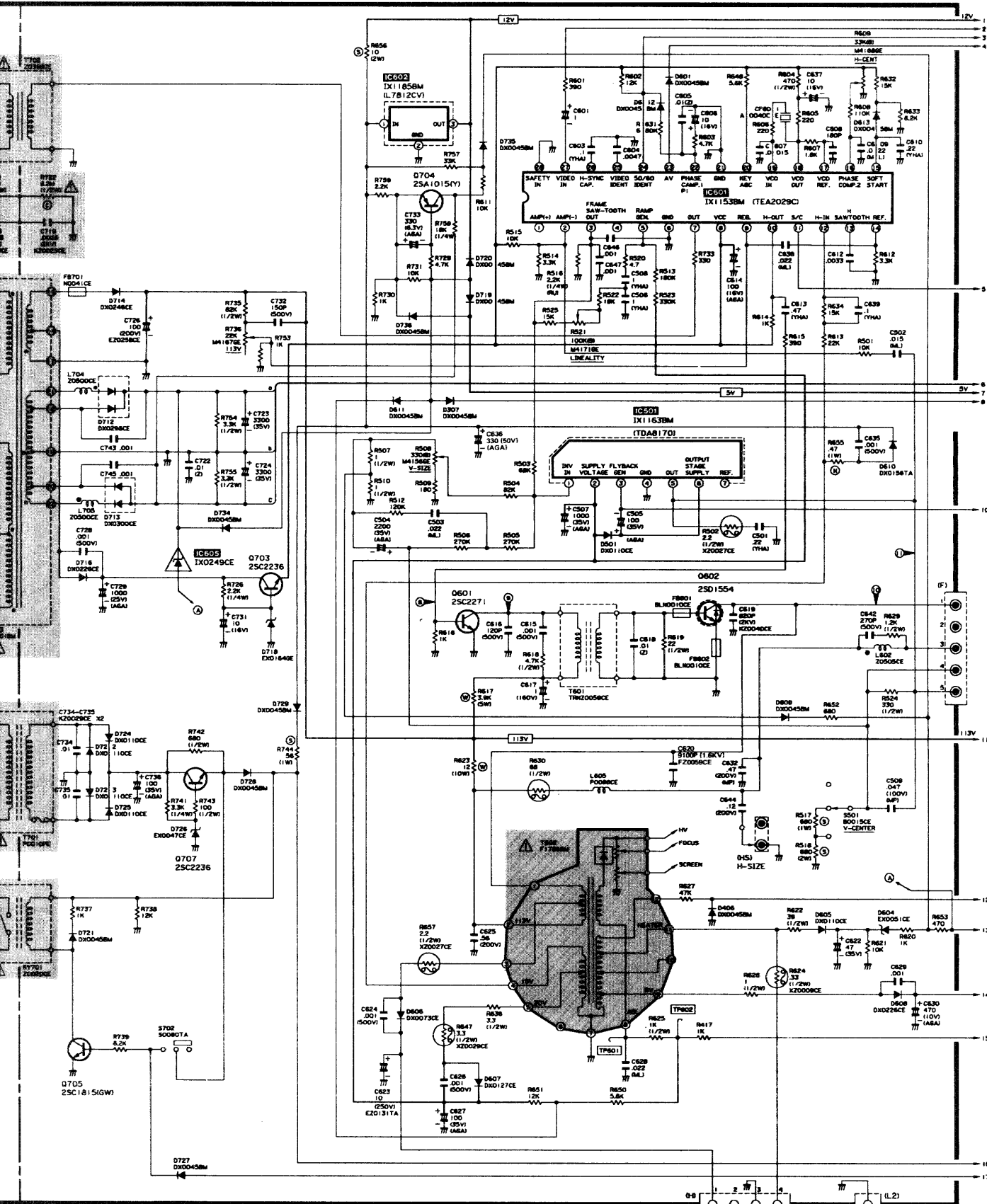

SCHEMATIC DIAGRAM (SV-2189H)

REN 136

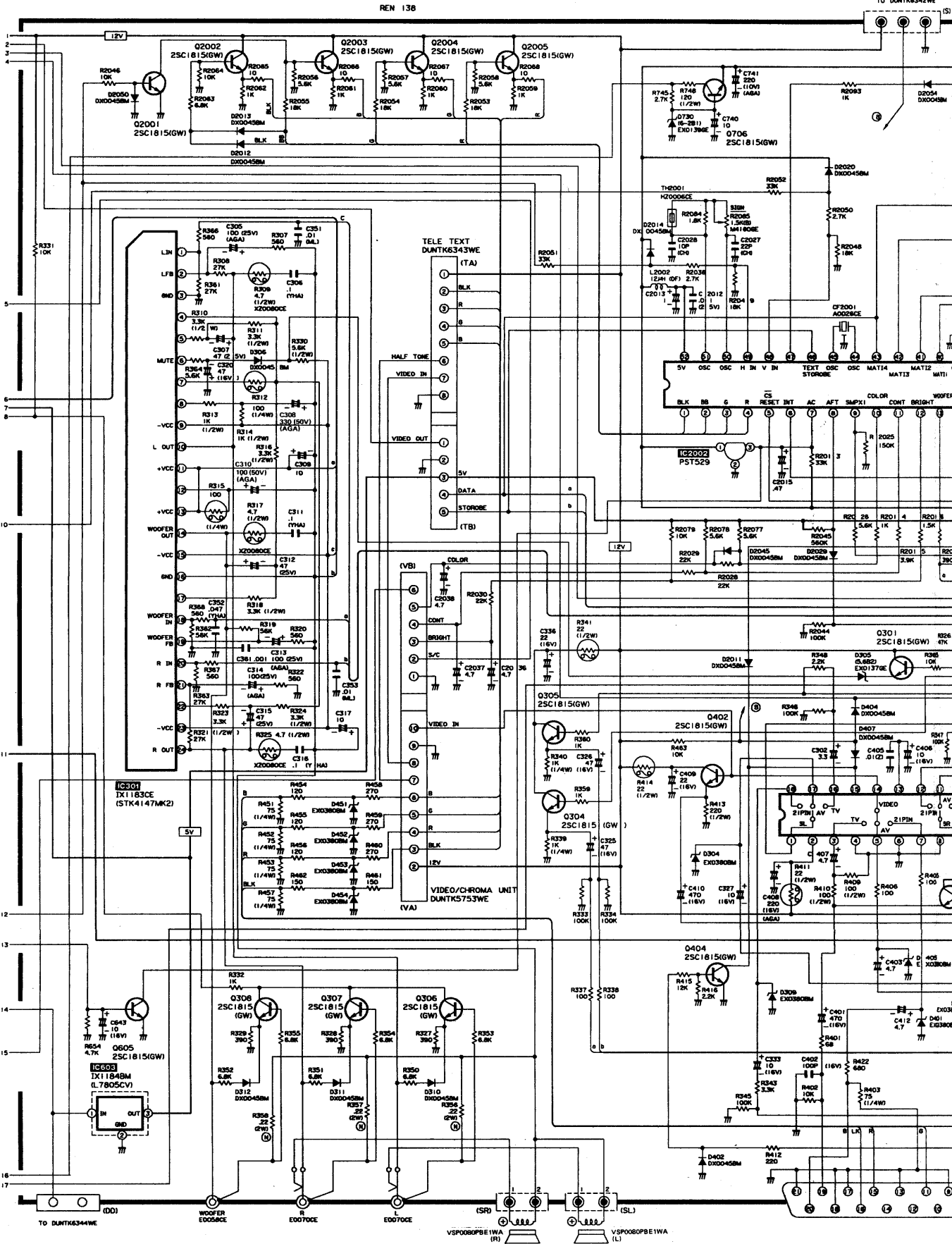

SV-2189H
SV-2589H
SV-2889H

SV-2189H
SV-2589H
SV-2889H

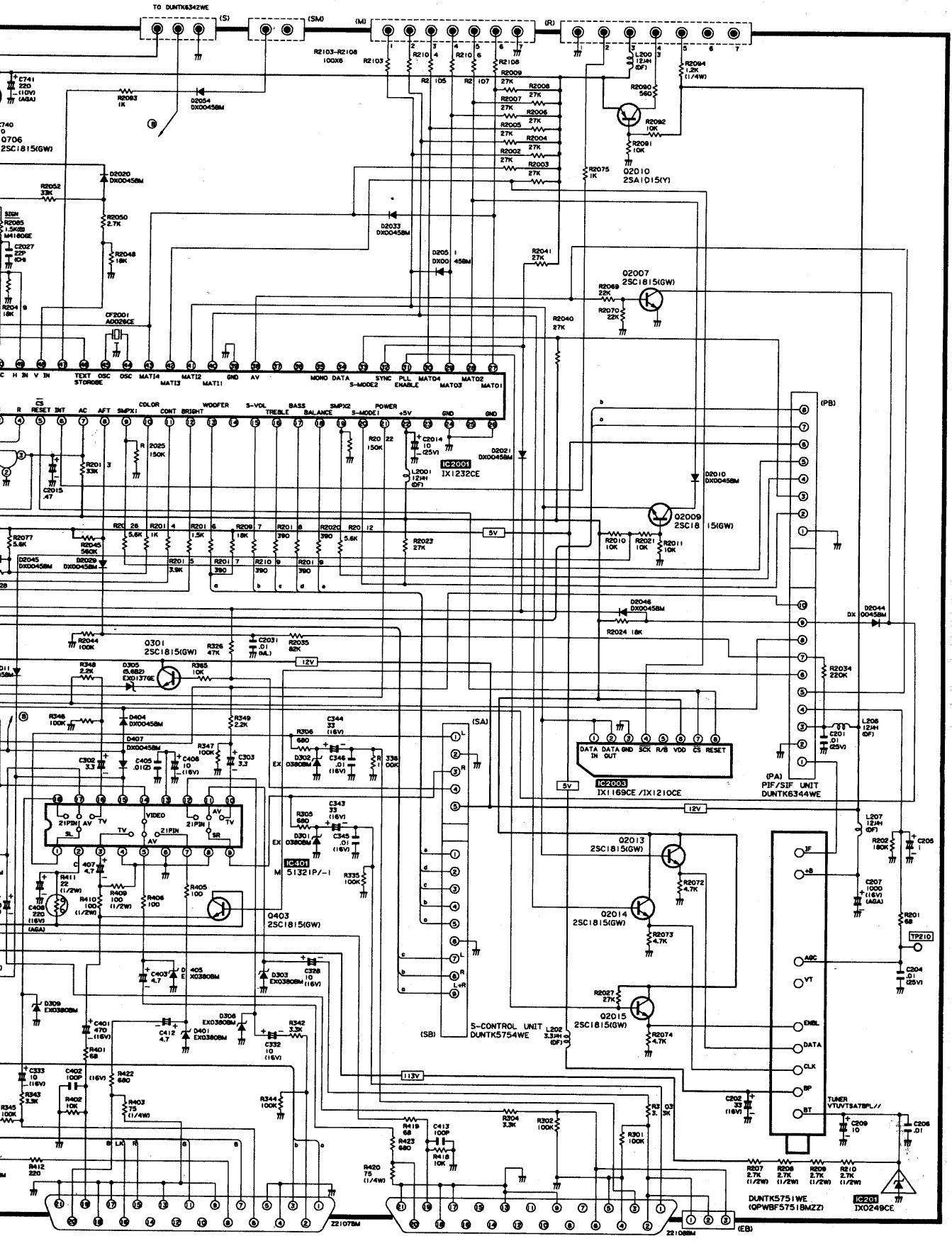

SCHEMATIC DIAGRAM

(SV-2189H)

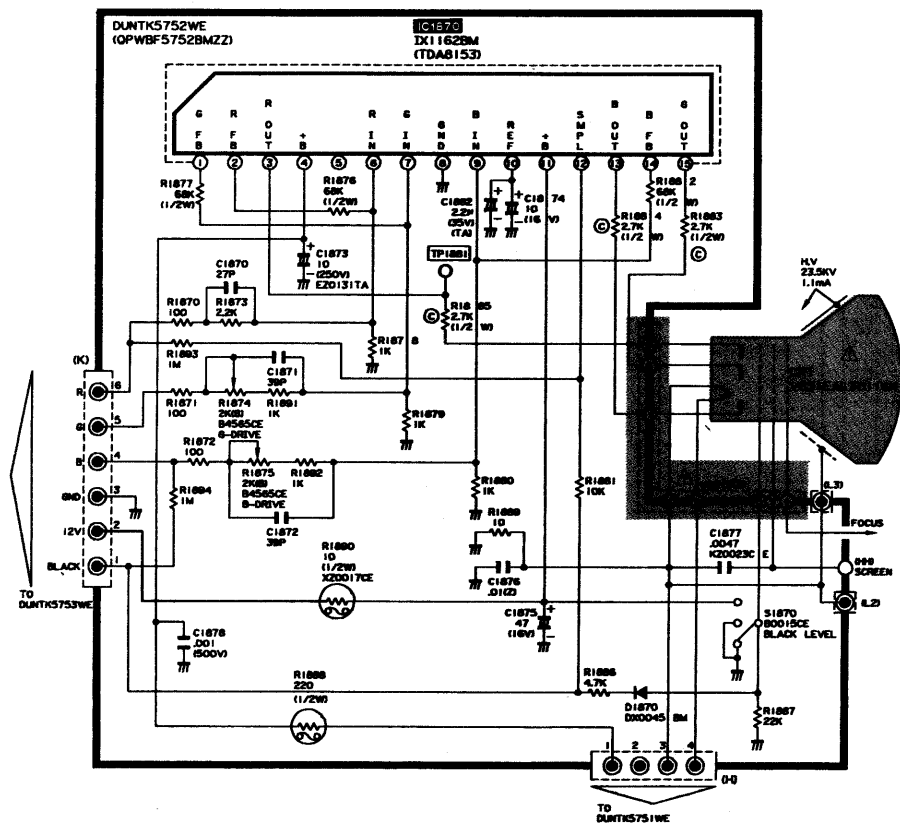

(SV-2589H/2889H)

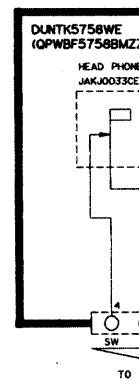
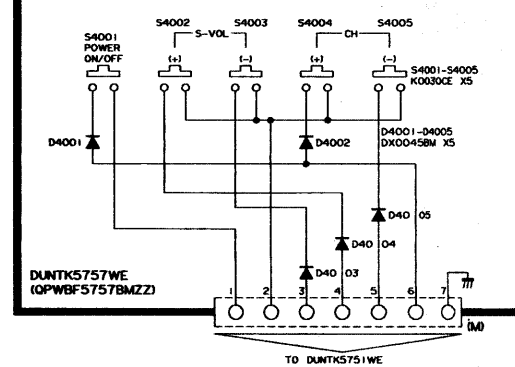
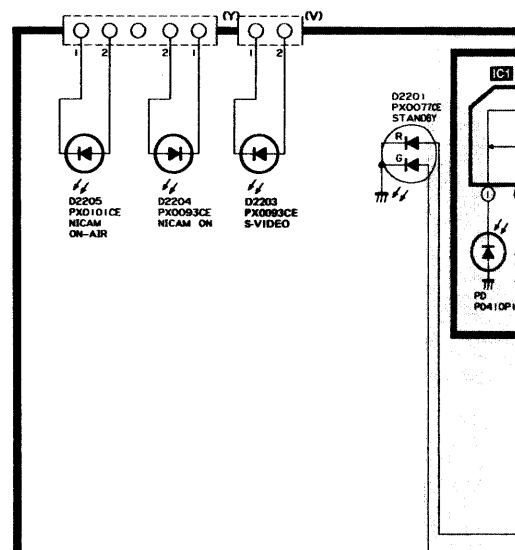
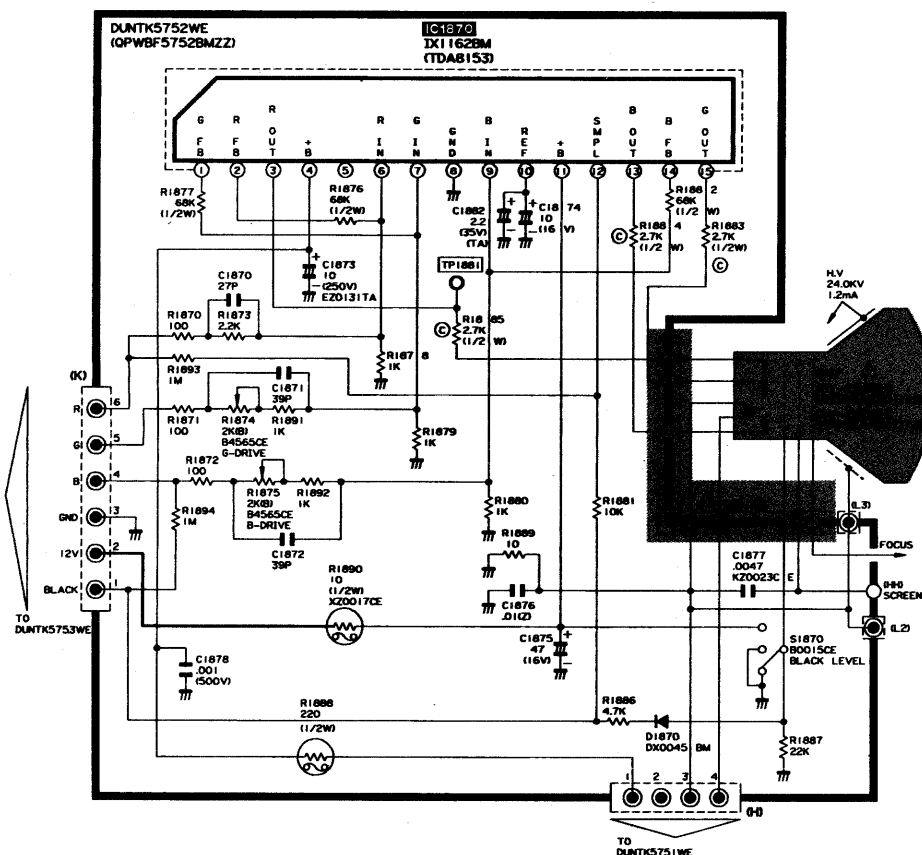

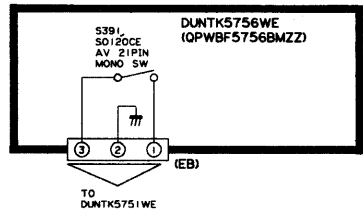
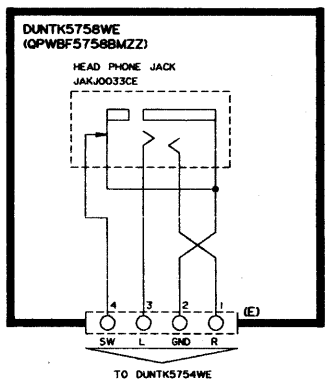
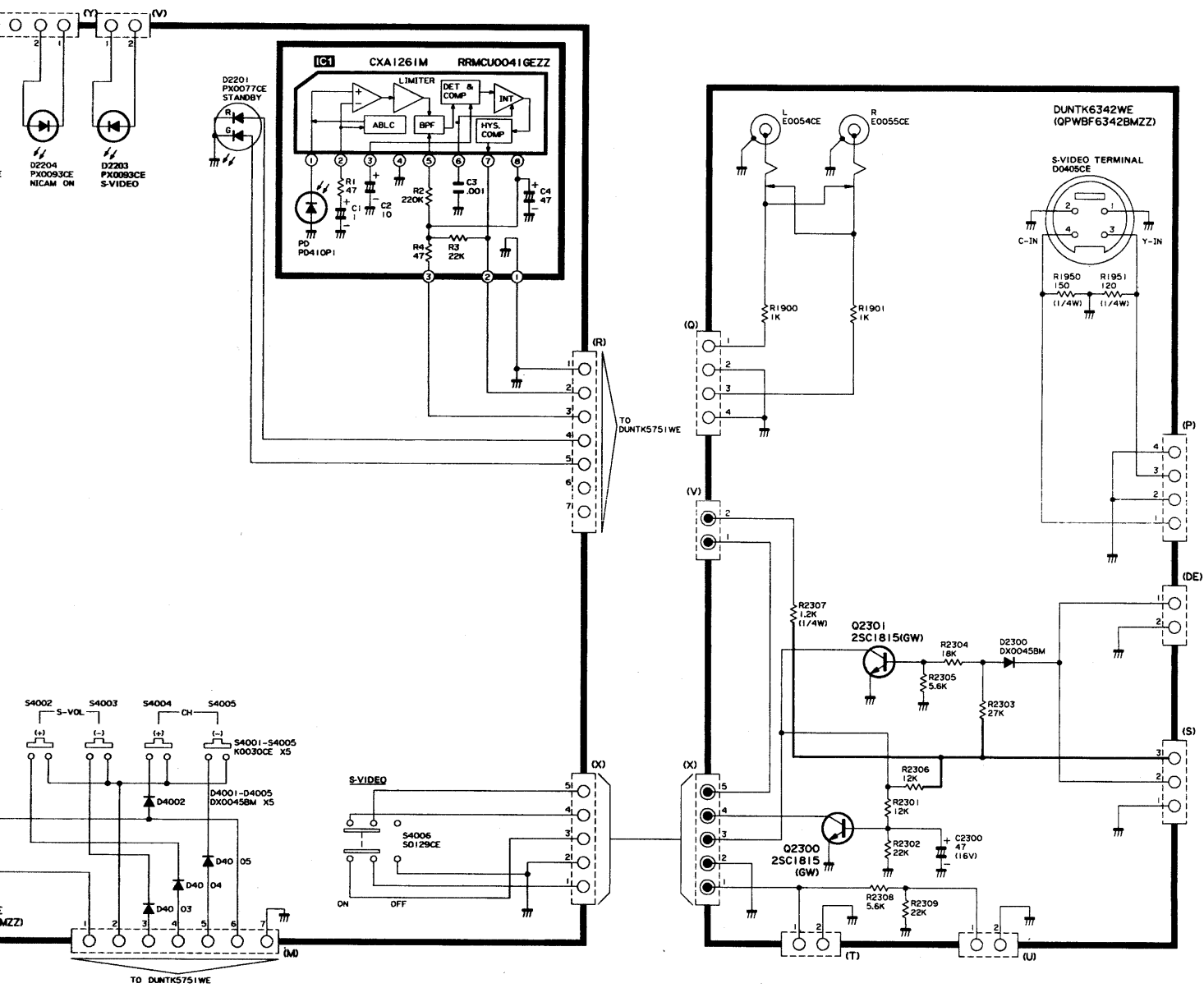

SCHEMATIC DIAGRAM

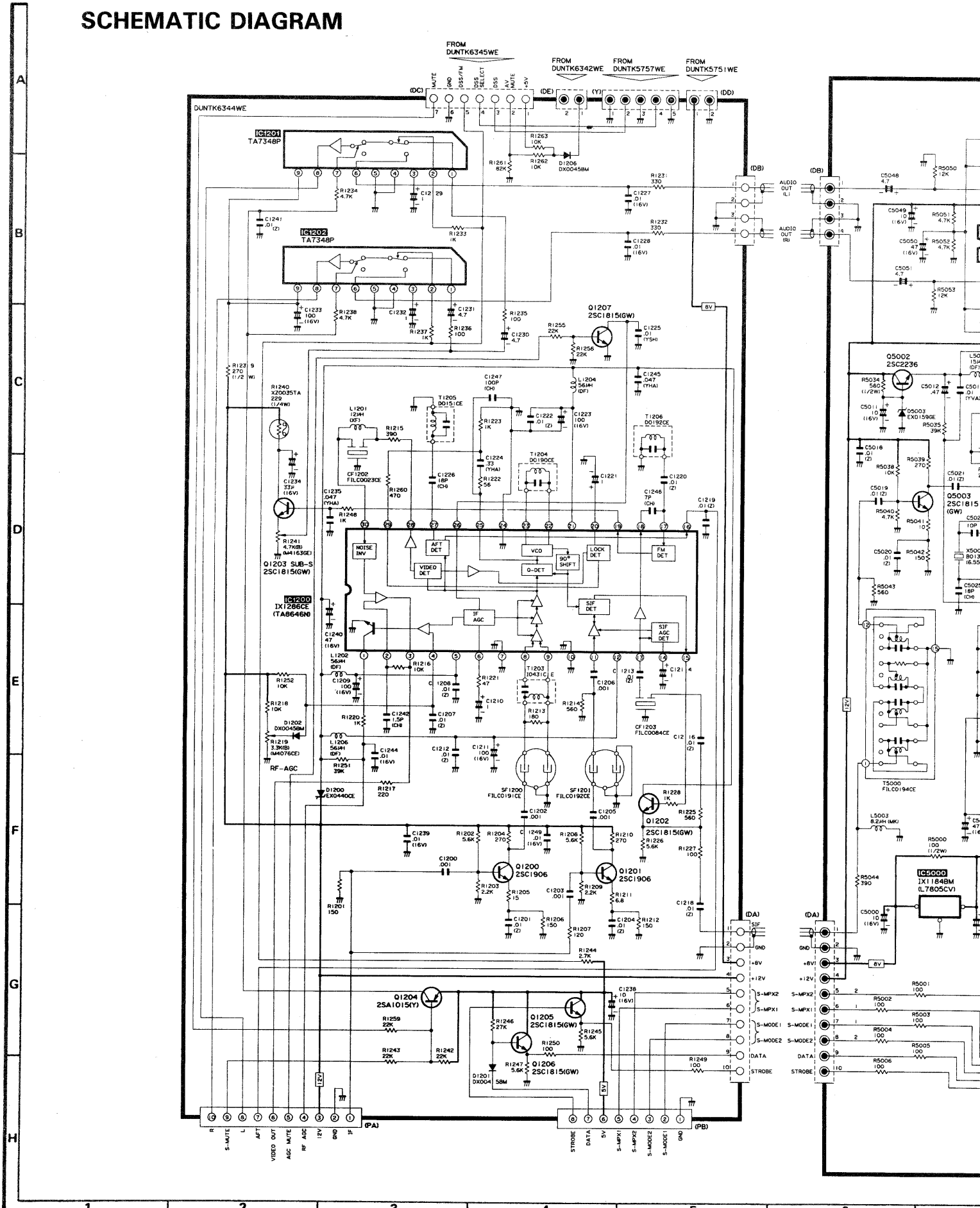

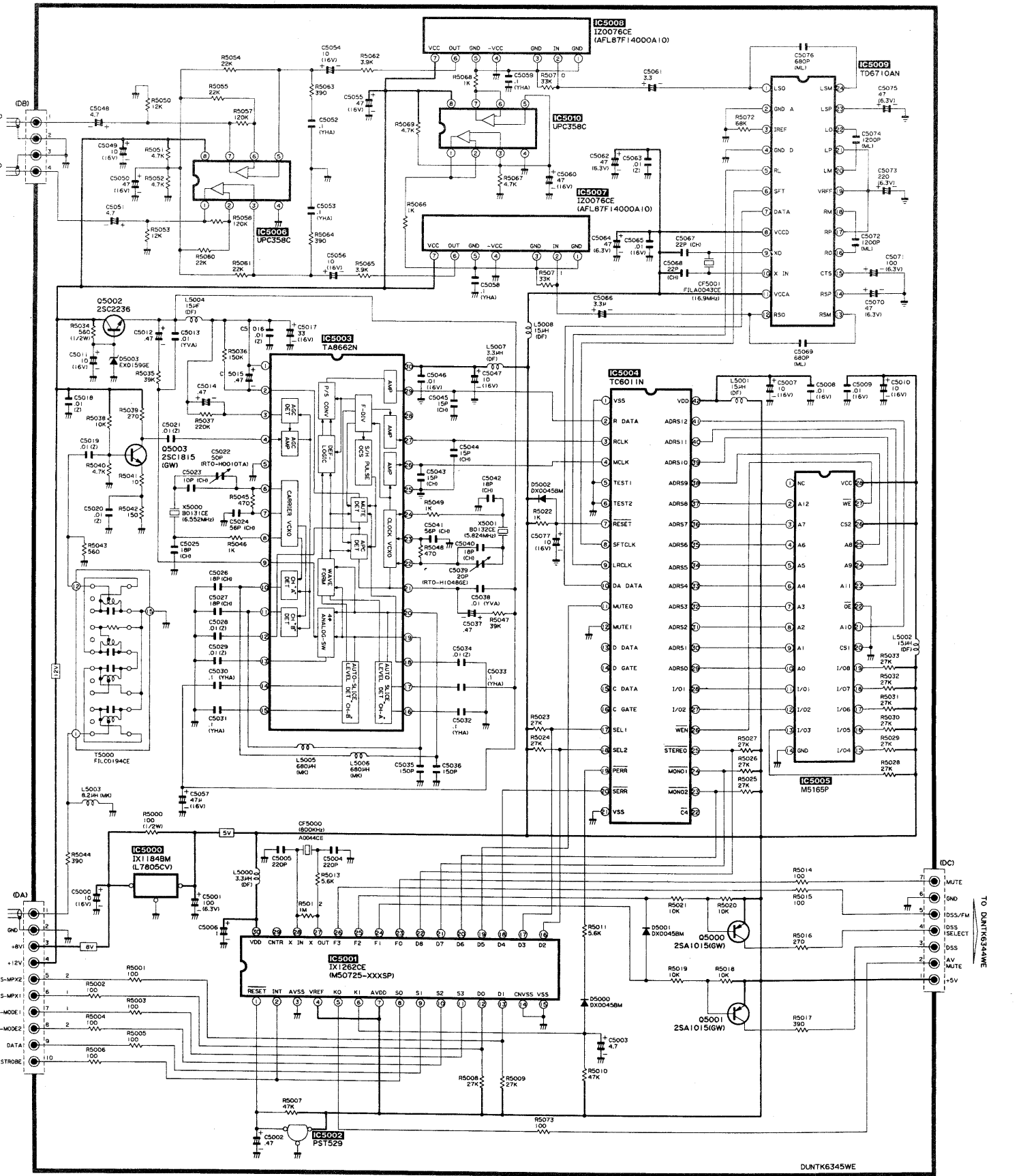

SCHEMATIC DIAGRAM

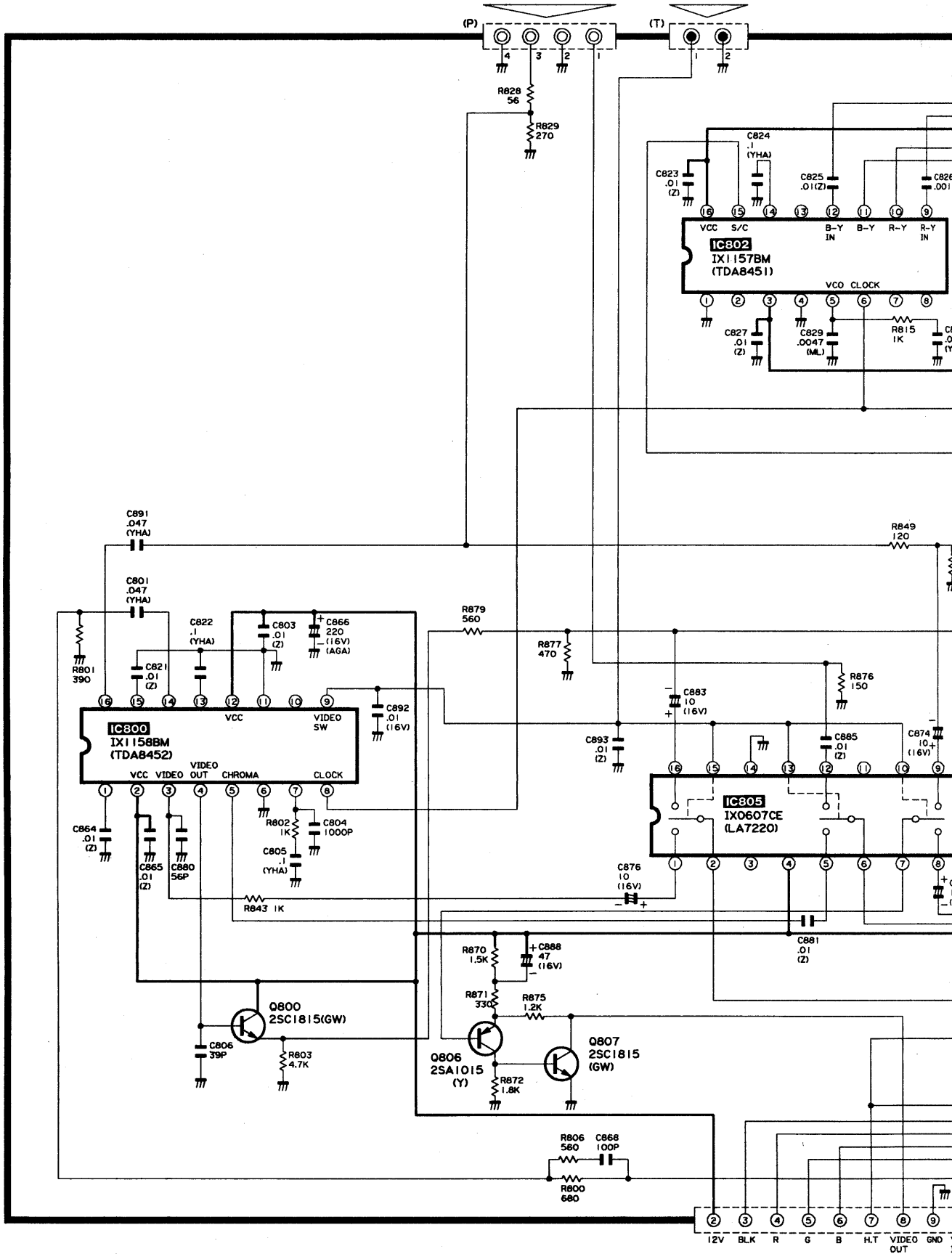

SV-2189H SV-2189H
 SV-2589H SV-2589H
 SV-2889H SV-2889H

DUNTK5753WE
 (QPWF5753BMZZ)

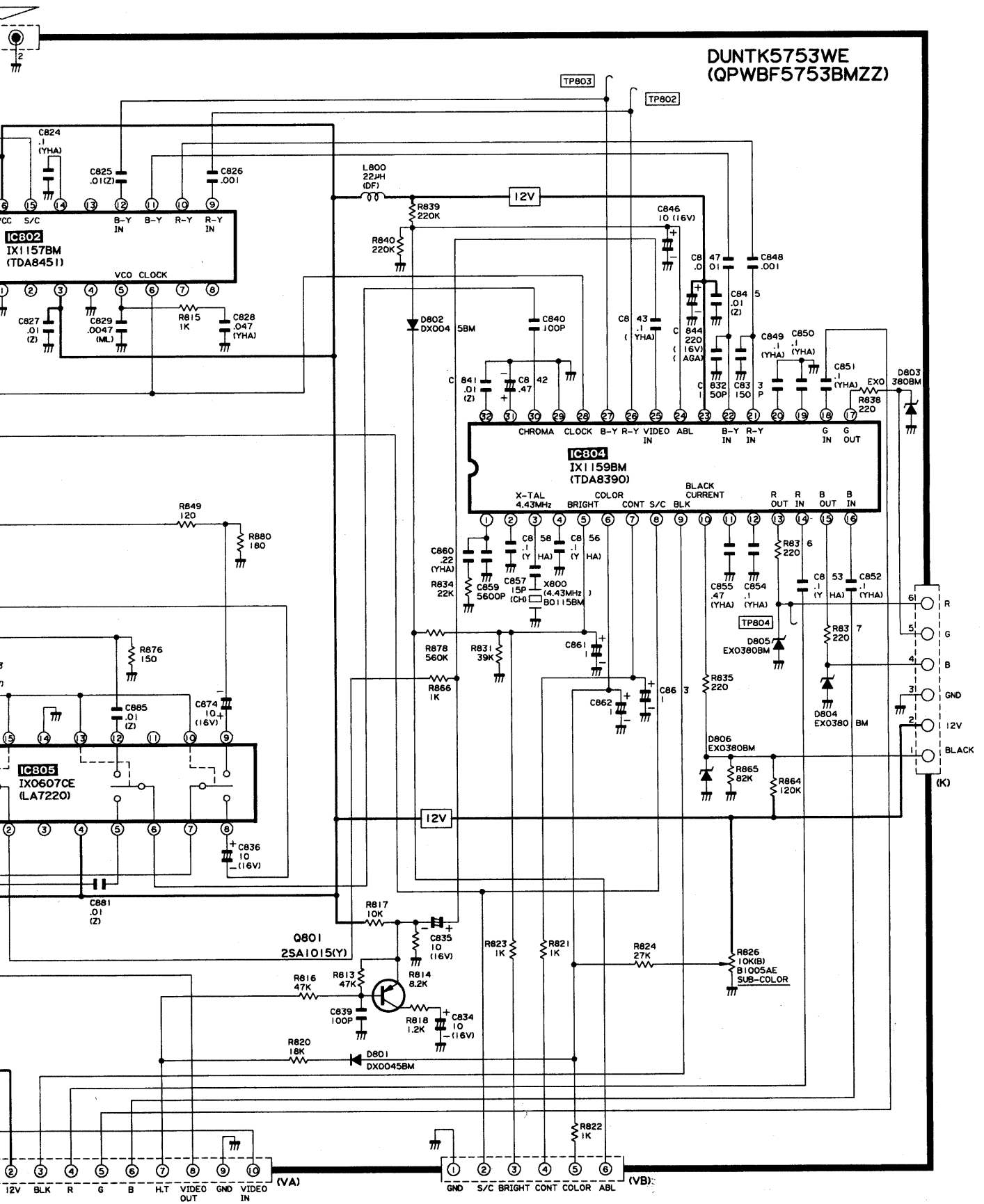

SCHEMATIC DIAGRAM

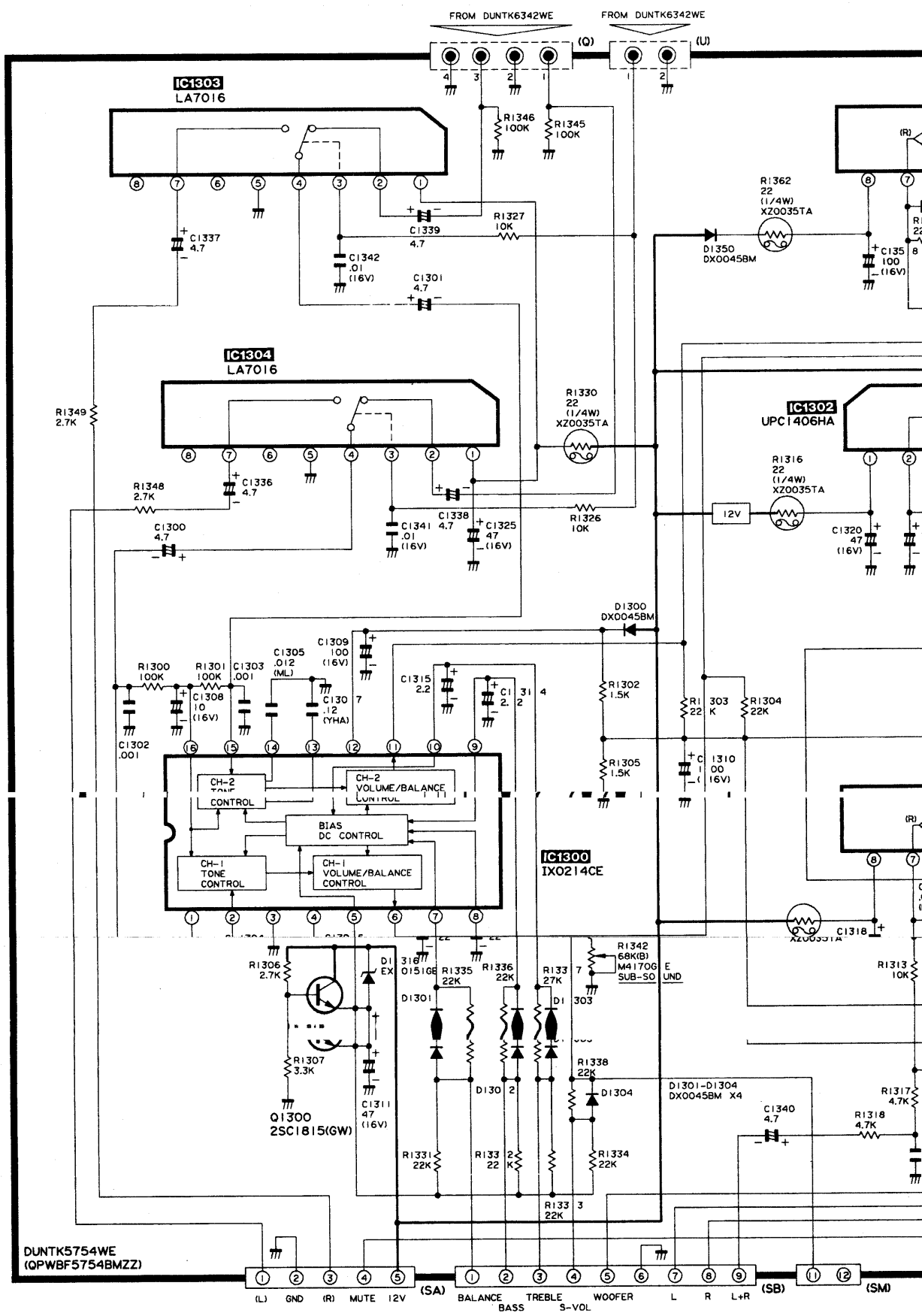

DUNT6342WE
 (QPWBF5754BMZZ)

SV-2189H SV-2189H
 SV-2589H SV-2589H
 SV-2889H SV-2889H

DUNT6342WE

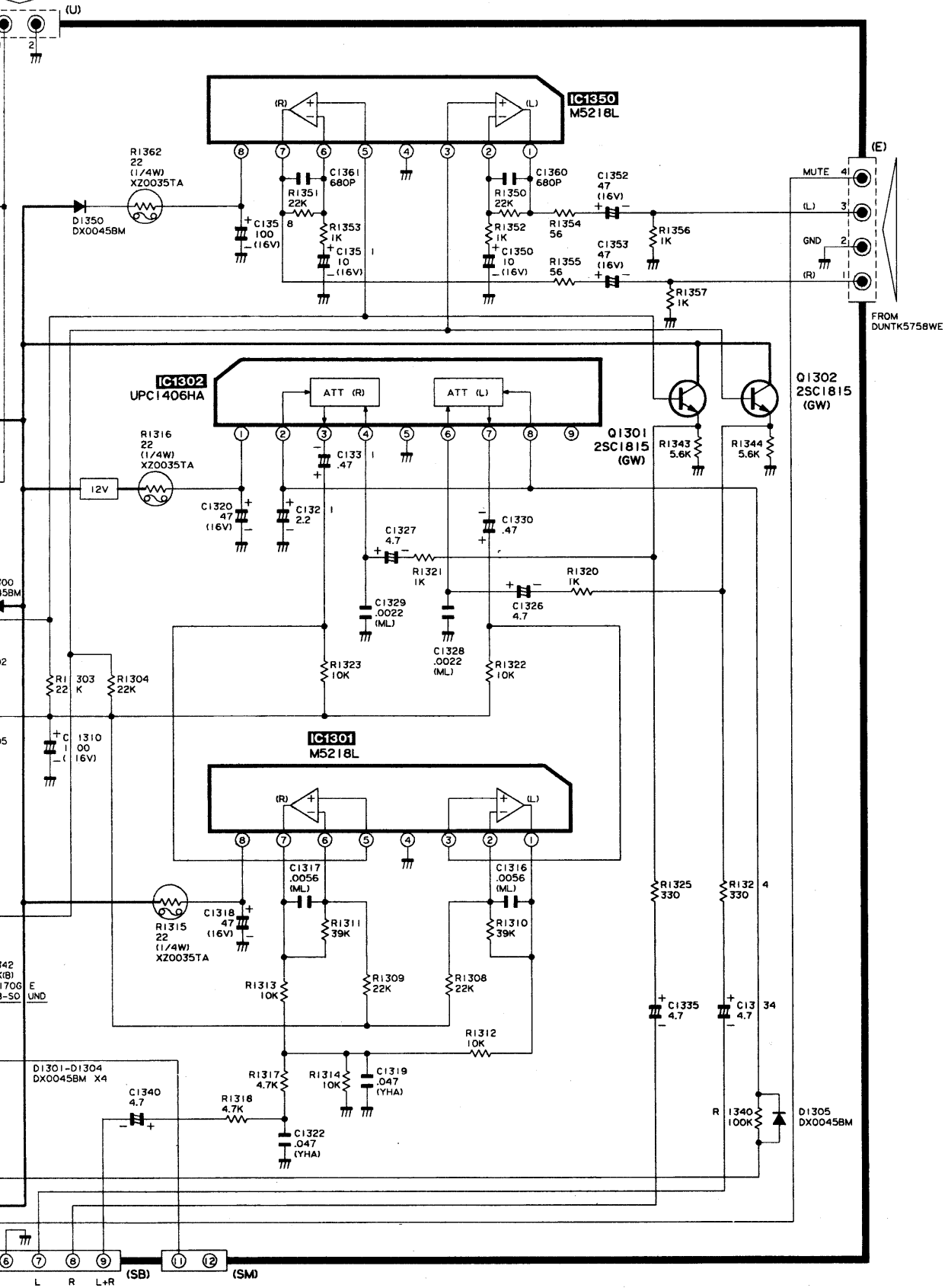

FROM DUNT65758WE

SCHEMATIC DIAGRAM

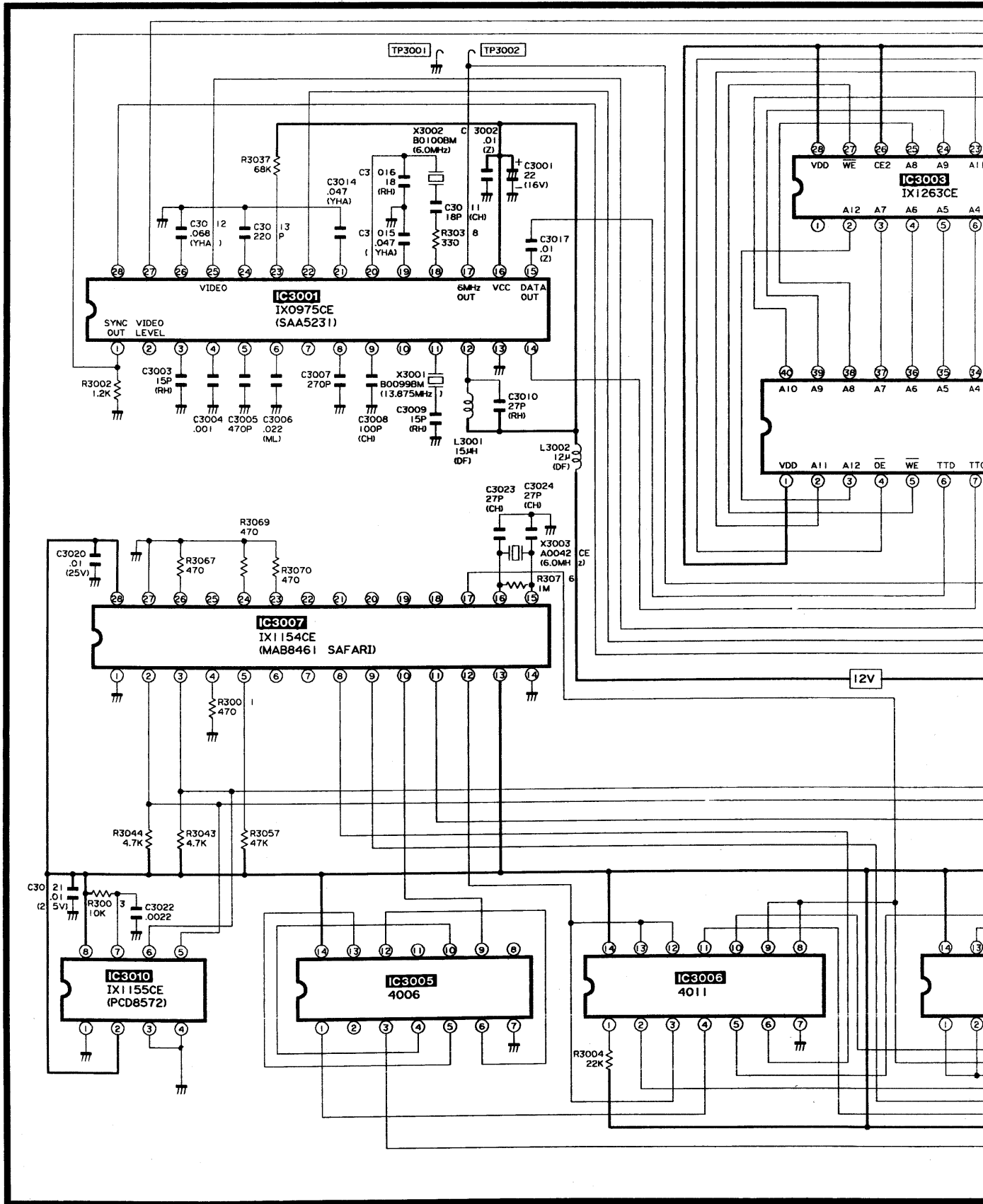

SV-2189H
SV-2589H
SV-2889H

SV-2189H
SV-2589H
SV-2889H

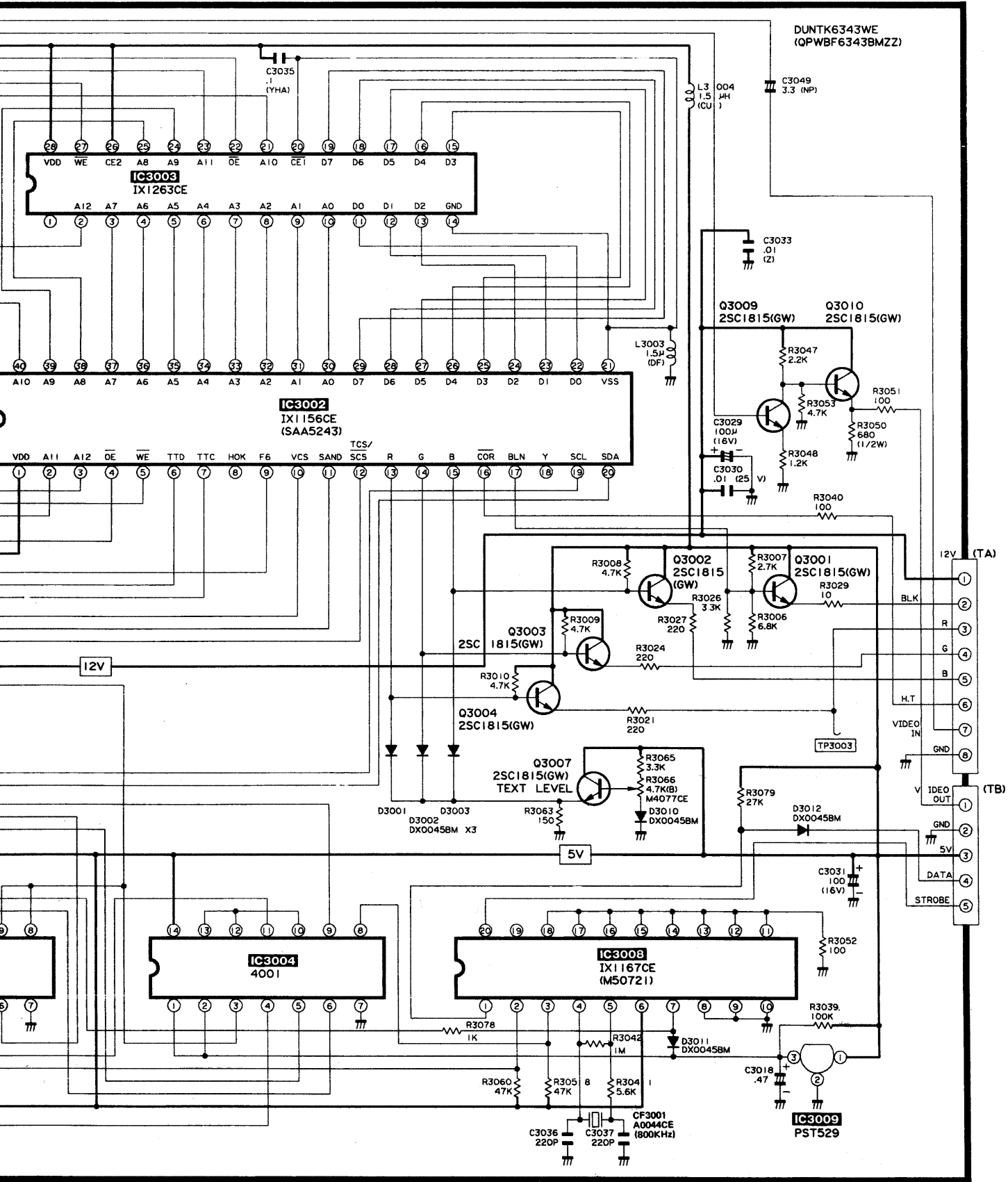

PARTS LIST

PARTS REPLACEMENT

Replacement parts which have these special safety characteristics identified in this manual; electrical components having such features are identified by Δ in the Replacement Parts Lists.

The use of a substitute replacement part which does not have the same safety characteristics as the factory recommended replacement parts shown in this service manual may create shock, fire or other hazards.

"HOW TO ORDER REPLACEMENT PARTS"

To have your order filled promptly and correctly, please furnish the following informations.

1. MODEL NUMBER
2. REF. NO.
3. PART NO.
4. DESCRIPTION
5. CODE

★ MARK: SPARE PARTS-DELIVERY SECTION

REF. NO.	PART NO.	*	DESCRIPTION	CODE
PICTURE TUBE				
Δ	VB51EAL3011*N	S	CRT (SV-2189H)	CU
Δ	VB59EAK0101*N	S	CRT (SV-2589H)	DE
Δ	VB66EAK5101*N	S	CRT (SV-2889H)	DG
Δ	CCi LG0311WEV2	S	Degaussing Coil (SV-2189H)	AW
Δ	CCi LG0303WEV1	S	Degaussing Coil (SV-2589H)	AW
Δ	CCi LG0304WEV1	S	Degaussing Coil (SV-2889H)	AW

PRINTED WIRING BOARD ASSEMBLIES (NOT REPLACEMENT ITEM)

DUNTK5751WEW1	S	Mother Unit (SV-2189H)	—
DUNTK5751WEW2	S	Mother Unit (SV-2589H)	—
DUNTK5751WEV7	S	Mother Unit (SV-2889H)	—
DUNTK5752WEW1	S	CRT Socket Unit (SV-2189H)	—
DUNTK5752WEW2	S	CRT Socket Unit (SV-2589H)	—
DUNTK5752WEV7	S	CRT Socket Unit (SV-2889H)	—
DUNTK5753WEV6	S	Video/Chroma Unit	—
DUNTK5754WEV3	S	Sound Control Unit	—
DUNTK5755WEV2	S	Side Pin Unit (SV-2589H)	—
DUNTK5755WEV5	S	Side Pin Unit (SV-2889H)	—
DUNTK5756WEV2	S	Switch Unit	—
DUNTK5757WEV4	S	Control Unit	—
DUNTK5758WEV2	S	Headphone Unit	—
DUNTK6342WEV0	S	S-VIDEO Terminal Unit	—
DUNTK6343WEV0	S	Text Unit	—
DUNTK6344WEV0	S	IF/S-MPX Unit	—
DUNTK6345WEV0	S	DSS Decoder Unit	—

REF. NO.	PART NO.	*	DESCRIPTION	CODE
MOTHER UNIT				
	DUNTK5751WEW1 (SV-2189H)			
	DUNTK5751WEW2 (SV-2589H)			
	DUNTK5751WEV7 (SV-2889H)			
TUNER				
NOTE: THE PARTS HERE SHOWN ARE SUPPLIED AS AN ASSEMBLY BUT NOT INDEPENDENTLY.				
	VTUVTSA7BPL//	S	VHF/UHF Tuner	BD
INTEGRATED CIRCUITS				
IC201, 604, 605	RH-i X0249CEZZ	J	(SV-2589H/2889H)	AE
IC301	RH-i X1183CEZZ	J		AZ
IC401	VHi M51321P/-1	J		AL
IC501	RH-i X1163BMZZ	S		AQ
IC601	RH-i X1153BMZZ	S		AW
IC602	RH-i X1185BMZZ	S		AG
IC603	RH-i X1184BMZZ	S		AG
IC701	RH-i X1152BMZZ	S		AS
IC2001	RH-i X1232CEZZ	J		AZ
	or			
IC2002	RH-i X1168CEZZ	J		AZ
IC2003	VHi PST529C2-1	J		AD
	or			
	RH-i X1210CEZZ	J		AN
	or			
	RH-i X1169CEZZ	J		AP
TRANSISTORS				
Q301, 304, 305, 306, 307, 308, 402, 403, 404, 605, 705, 706, 2001 2005, 2007, 2009, 2013, 2014, 2015	VS2SC1815GW-1	J	2SC1815(GW)	AB
Q601	VS2SC2271-D1A	J	2SC2271	AD
Q602	VS2SD1554//2E	J	2SD1554 (SV-2189H)	AL
Q602, 701	VS2SD1546//1E	J	2SD1546 (SV-2589H/2889H)	AP
Q703, 707	VS2SC2236Y/-1	J	2SC2236	AD
Q704, 2010	VS2SA1015Y/1E	J	2SA1015(Y)	AC

REF. NO.	PART NO.	*	DESCRIPTION	CODE	REF. NO.	PART NO.	*	DESCRIPTION	CODE
DIODES									
D301, 302, 303, 304, 308, 309, 401, 405, 451, 452, 453, 454	RH- EX0380BMZZ	S	Zener Diode	AB	D604	RH- EX0051CEZZ	J	Zener Diode	AB
D305, D306, 307, 310, 311, 312, 402, 404, 406, 407, 601, 609, 611, 612, 613, 705, 719, 720, 721, 727, 728, 729, 734, 735, 736, 2010, 2011, 2012, 2013, 2014, 2020, 2021, 2029, 2033, 2044, 2045, 2046, 2050, 2051, 2054	RH- EX0137GEZZ RH- DX0045BMZZ	J S	Zener Diode 1N4148	AA AA	D606	RH- DX0073CEZZ	J		AD
307, 310, 311, 312, 402, 404, 406, 407, 601, 609, 611, 612, 613, 705, 719, 720, 721, 727, 728, 729, 734, 735, 736, 2010, 2011, 2012, 2013, 2014, 2020, 2021, 2029, 2033, 2044, 2045, 2046, 2050, 2051, 2054					D607	RH- DX0127CEZZ	J		AC
D501, 605, 707, 708, 709, 722, 723, 724, 725	RH- DX0110CEZZ	J		AB	D608, 716	RH- DX0226CEZZ	J		AC
D602	RH- DX0299BMZZ	S	BY228 (SV-2589H/2889H)	AK	D610	RH- DX0156TAZZ	J		AD
D603	RH- DX0301BMZZ	S	BY299 (SV-2589H/2889H)	AU	D701, 702, 703, 704	RH- DX0240CEZZ	J		AB
					D706,	RH- DX0130CEZZ	J		AE
					D712	RH- DX0296CEZZ	J		AG
					D713	RH- DX0300CEZZ	J		AG
					D714	RH- DX0246CEZZ	J		AD
					D718	RH- EX0164GEZZ	J	Zener Diode	AB
					D726	RH- EX0047CEZZ	J	Zener Diode	AB
					D730	RH- EX0139GEZZ	J	Zener Diode	AA
					D731, 732	RH- DX0117TAZZ	J		AB
					TH2001	RH- HZ0006CEZZ	J	Thermistor	AB
					PACKAGED CIRCUITS				
					PR701	RMPTP0028CEZZ	J	Positive Coefficient Thermistor	AG
					COILS				
					L202	VP- DF3R3K0000	J	3.3μH	AB
					L206, 207, 2001, 2002, 2003	VP- DF120K0000	J	12μH	AB
					L602	RCi LZ0505CEZZ		(SV-2189H)	AF
					L602	RCi LZ0599CEZZ	J	(SV-2589H/2889H)	AG
					L603	RCi LP0104CEZZ	J	(SV-2589H/2889H)	AG
					L604, 605	RCi LP0088CEZZ	J	3.3μH	AG
					L605	RCi LP0105CEZZ	J	(SV-2589H/2889H)	AG
					L701	RCi LF0139CEZZ	J	Line Filter	AQ
					L703	VP- CF2R2M0000	J	2.2μH	AB
					L704, 705	RCi LZ0500CEZZ	J		AF
					CERAMIC FILTERS				
					CF601	RFi LA0040CEZZ	J		AD
					CF2001	RFi LA0026CEZZ	J		AE
					TRANSFORMERS				
					T601	RTRNZ0059CEZZ	J	Horizontal Drive Trans. (SV-2189H)	AF
					ΔT602	RTRNF1786BMZZ	S	(SV-2189H)	BH
					ΔT602	RTRNF1783BMZZ	S	F.B.T. (SV-2589H/2889H)	BH
					ΔT701	RTRNP0010PEZZ	R	R/C Power Trans.	AY
					ΔT702	RTRNZ0368CEZZ	J	Trigger Trans.	AE
					ΔT703	RTRNZ0401BMZZ	S	Choppr Trans. (SV-2189H)	AZ
					ΔT703	RTRNZ0369BMZZ	S	Chopper Trans. (SV-2589H/2889H)	AZ

REF. NO.	PART NO.	*	DESCRIPTION	CODE	REF. NO.	PART NO.	*	DESCRIPTION	CODE
CONTROLS					ΔC701, Δ 702	RC- FZ0070BMZZ	S	0.1 250V Metalized Polyester	AF
R508	RVR- M4156GEZZ	J	330(B) Vertical Size	AB	C703,	RC- KZ0029CEZZ	J	0.01 250V Ceramic	AC
R521	RVR- M4171GEZZ	J	100K(B) Vertical Linearity (SV-2189H)	AB	704, 705, 706, 734, 735				
R521	RVR- M4174GEZZ	J	330K(B) Vertical Linearity (SV-2589H/2889H)	AB	C707	RC- EZ0239CEZZ	J	330 400V Electrolytic	AS
R609	RVR- M4168GEZZ	J	33K(B) Horizontal Center	AB	C712	VCEAGA1EW227M	J	220 25V Electrolytic	AC
R736	RVR- M4167GEZZ	J	22K(B) 113V (SV-2189H)	AB	ΔC718,	RC- KZ0023CEZZ	J	0.00472kV Ceramic	AD
R736	RVR- M4169GEZZ	J	47K(B) 150V (SV-2589H/2889H)	AB	Δ 719				
R2085	RVR- M4160GEZZ	J	1.5K(B) Sign Adjust	AB	C720	VCFPPD3CA222J	J	2200P 1.6kV Metalized Polyester	AD
CAPACITORS					C723, 724	VCEAHH1VN338M	J	3300 35V Electrolytic	AH
C207	VCEAGA1CW108M	J	1000 16V Electrolytic	AD	C726	RC- EZ0217CEZZ	J	100 200V Electrolytic	AL
C305, 313, 314	VCEAGA1EW107M	J	100 25V Electrolytic	AD		or			
C308, 636	VCEAGA1HW337M	J	330 50V Electrolytic	AD	C729	RC- EZ0258CEZZ	J		AH
C310	VCEAGA1HW107M	J	100 50V Electrolytic	AC	C732	VCEAGA1EW108M	J	1000 25V Electrolytic	AD
C401, 410	VCEAAA1CW477M	J	470 16V Electrolytic	AC	C733	VCKYPA2HB151K	J	150P 500V Ceramic	AA
C408	VCEAGA1CW227M	J	220 16V Electrolytic	AC	C741	VCEAGAOJW337M	J	330 6.3V Electrolytic	AB
C504	VCEAGH1VW228M	J	2200 35V Electrolytic	AG		VCEAGA1AW227M	J	220 10V Electrolytic	AB
C505, 627, 736	VCEAGA1VW107M	J	100 35V Electrolytic	AC	RESISTORS				
C507	VCEAGA1VW108M	J	1000 35V Electrolytic	AD	R309, 317, 325, 719	RR- XZ0080CEZZ	J	4.7 1/2W Fuse Resistor	AB
C509	VCFYSB2AB473K	J	0.047 100V Metallized Polypro	AC	R312, 315	VRG- RF2EB101J	J	100 1/4W Fuse Resistor (SV-2589H/2889H)	AB
C614	VCEAGA1CW107M	J	100 16V Electrolytic	AB	R341, 411, 414	VRG- RL2HB220J	J	22 1/2W Fuse Resistor	AB
C615, 624, 626, 635, 715, 716, 717, 728	VCKYPA2HB102K	J	1000P 500V Ceramic	AA	R356, 357, 358	VRN- VV3DBR22J	J	0.22 2W Metal Film	AB
C616	VCCSPA2HL121K	J	120P 500V Ceramic	AA	R502, 657	RR- XZ0027CEZZ	J	2.2 1/2W Fuse Resistor	AB
C617	VCEAAA2CW105M	J	1 160V Electrolytic	AB	R517	VRS- VV3AB681J	J	680 1W Metal Oxide (SV-2189H)	AA
C619	RC- KZ0040CEZZ	J	820P 2kV Ceramic (SV-2189H)	AD	R517	VRS- VV3AB331J	J	330 1W Metal Oxide (SV-2589H/2889H)	AA
C619	RC- KZ0024CEZZ	J	0.001 2kV Ceramic (SV-2589H/2889H)	AC	R518	VRS- VV3DB681J	J	680 2W Metal Oxide (SV-2189H)	AA
C620	RC- FZ0059CEZZ	J	0.00912kV Metalized Polyester	AE	R518	VRS- VV3LB331J	J	330 3W Metal Oxide (SV-2589H/2889H)	AB
C621	VCQPSC2GA273K	J	0.027 400V Polypro Film (SV-2589H/2889H)	AB	R617	VRW- KX3HC392K	J	3.9K 5W Cemet (SV-2189H)	AD
C623	RC- EZ0131TAZZ	J	10 250V Electrolytic	AD	R617	VRW- KX3HC682K	J	6.8K 5W Cement (SV-2589H/2889H)	AD
C625,	VCFPPD2DB474J	J	0.47 200V Metalized Polyester (SV-2589H/2889H)	AE	R623	VRW- KX4AC120K	J	12 10W Cement (SV-2189H)	AD
631, 632					R623	VRW- KX4AC100K	J	10 10W Cement (SV-2589H/2889H)	AD
C630	VCEAGA1AW477M	J	470 10V Electrolytic	AC	R624	RR- XZ0009CEZZ	J	0.33 1/2W Fuse Resistor (SV-2189H)	AC
C634	VCFPPC2DB474J	J	0.47 200V Metalized Polyester (SV-2589H/2889H)	AE	R624	VRN- SV2HBR22J	J	0.22 1/2W Metal Film (SV-2589H/2889H)	AA
C642	VCKYPA2HB271K	J	270P 500V Ceramic	AA	R626	VRG- RL2HB390J	J	39 1/2W Fuse Resistor (SV-2589H/2889H)	AB
C644	VCFPPB2DB124J	J	0.12 200V Metalized Polyester (SV-2189H)	AE	R630	VRG- RL2HB680J	J	68 1/2W Fuse Resistor (SV-2189H)	AB
					R647	RR- XZ0029CEZZ	J	3.3 1/2W Fuse Resistor (SV-2189H)	AB
					R647	VRG- RL2HB1R0K	J	1 1/2W Fuse Resistor (SV-2589H/2889H)	AB

REF. NO.	PART NO.	*	DESCRIPTION	CODE	REF. NO.	PART NO.	*	DESCRIPTION	CODE
R655	VRN- VV3ABR47J	J	0.47 1W Metal Film	AA	R1888	VRG- RL 2HB 221J	J	220 1/2W Fuse Resistor	AB
R656	VRS- VV3DB100J	J	10 2W Metal Oxide	AA	R1890	RR- XZ0017CEZZ	J	10 1/2W Fuse Resistor	AB
R701	VRW- KX41C4R7K	J	4.7 15W Cement	AE	SWITCH				
R719	VRG- RL 2HB6R8J	J	6.8 1/2W Fuse Resistor (SV-2189H)	AB					
R720	RR- XZ0017CEZZ	J	10 1/2W Fuse Resistor	AB	MISCELLANEOUS PARTS				
ΔR721, Δ 722	VRC- UA2HG825K	J	8.2M 1/2W Solid	AA					
R732	VRW- KX3HC221K	J	220 5W Cement	AD	S1870	QSW- B0015CEZZ	J	Black Level Adj.	AC
R744	VRS- VV3AB560J	J	56 1W Metal Oxide	AA	VIDEO/CHROMA UNIT				
R752	VRW- KP3HCR27K	J	0.27 5W Cement	AC					
SWITCHES					Δ	QSDCV0913CEZZ	J	CRT Socket	AK
S501	QSW- B0015CEZZ	J	V-Center	AC	INTEGRATED CIRCUITS				
ΔS701	QSW- P0418CEZZ	J	Power	AK					
S702	QSW- S0060TAZZ	J	Aging	AD					
MISCELLANEOUS PARTS					INTEGRATED CIRCUITS				
ΔF701	QFS- C2024CEZZ	J	Fuse T2A	AD	IC800	RH- i X1158BMZZ	S		AU
	QFSDH1002CEZZ	J	Fuse Holder	AA	IC802	RH- i X1157BMZZ	S		AU
FB601, 602	RBLN- 0010CEZZ	J	Ferrite Bead	AC	IC804	RH- i X1159BMZZ	S		BA
FB701	RBLN- 0041CEZZ	J	Ferrite Bead	AB	IC805	RH- i X0607CEZZ	J		AK
ΔRY701	RRLYZ0020CEZZ	J	Reley	AN	TRANSISTORS				
	QJAKE0058CEZZ	J	Jack, Woofer	AG					
	QJAKE0070CEZZ	J	Jack, L/R	AD	Q800, 807	VS2SC1815GW- 1	J	2SC1815(GW)	AB
DUNTK5752WEW1 (SV-2189H) DUNTK5752WEW2 (SV-2589H) DUNTK5752WEV7 (SV-2889H) CRT SOCKET UNIT					Q801, 806	VS2SA1015Y/ 1E	J	2SA1015(Y)	AC
					DIODES				
					INTEGRATED CIRCUIT				
IC1870	RH- i X1162BMZZ	S		AR	D801, 802	RH- DX0045BMZZ	S		AA
DIODE					D803, 804, 805, 806	RH- EX0380BMZZ	S	Zener Diode	AB
D1870	RH- DX0045BMZZ	S		AA	PACKAGED CIRCUIT				
CONTROLS					X800	RCRSB0115BMZZ	S	Cristal-4.43MHz	AL
R1874, 1875	RVR- B4565CEZZ	J	2K(B) G-Drive B-Drive	AC	COIL				
CAPACITORS					L800	VP- DF220K0000	J	22μF	AB
C1873	RC- EZ0131TAZZ	J	10 250V Electrolytic	AD	CONTROL				
C1877	RC- KZ0023CEZZ	J	0.0047 Ceramic	AD	R826	RVR- B1005AEZZ	J	10K(B) Sub-Colour	AB
C1878	VCKYPA2HB102K	J	1000P 500V Ceramic	AA	CAPACITORS				
C1882	VCSATA1VE225K	J	2.2 35V Tantalum	AC	C844, 866	VCEAGA1CW227M	J	220 16V Electrolytic	AC
RESISTORS									
R1883, 1884, 1885	VRC- MA2HG272K	J	2.7K 1/2W Solid	AA					

REF. NO.	PART NO.	*	DESCRIPTION	CODE	REF. NO.	PART NO.	*	DESCRIPTION	CODE
DUNTK5754WEV3 S-CONTROL UNIT					RESISTOR				
INTEGRATED CIRCUITS					R1618	RR- XZ0027CEZZ	J	2.2 1/2W Fuse Resistor	AB
IC1300	RH- i X0214CEZZ	J		AP	DUNTK5756WEV2 SWITCH UNIT				
IC1301, 1350	VHi M5218L / - 1	J		AF	SWITCH				
IC1302	VHi UPC1406HA1	J		AH	S391	QSW- S0120CEZZ	J	Mono Switch	AC
IC1303, 1304	VHi LA7016 / - 1	J		AH	DUNTK5757WEV4 CONTROL UNIT				
TRANSISTORS					DIODES				
Q1300, 1301, 1302	VS2SC1815GW- 1	J	2SC1815(GW)	AB	D2201	RH- PX0077CEZZ	J	LED	AE
DIODES					D2203, 2004	RH- PX0093CEZZ	J	LED	AB
D1300	RH- DX0045BMZZ	S	1N4148	AA	D2205	RH- PX0101CEZZ	J	LED	AB
1305, 1350					D4001	RH- DX0045BMZZ	S	1N4148	AA
D1316	RH- EX0151GEZZ	J	Zener Diode	AA	4005				
CONTROL					SWITCHES				
R1342	RVR- M4170GEZZ	J	68K(B) Sub-Sound	AB	S4001, 4002, 4003, 4004, 4005	QSW- K0030CEZZ	J	Switch, Power, S-VOL (+), S-VOL (-), CH (+), CH (-)	AB
CAPACITORS					S4006	QSW- S0129CEZZ	J	Switch, S-VIDEO	AC
C1309, 1310, 1358	VCEAAA1CW107M	J	100 16V Electrolytic	AB	MISCELLANEOUS PARTS				
RESISTORS						RRMCU0041GEZZ	J	Remote Control Receiver	AL
R1315, 1316, 1330, 1362	RR- XZ0035TAZZ	J	22 1/4W Fuse Resistor	AB	DUNTK5758WEV2 HEADPHONE UNIT				
DUNTK5755WEV2 (SV-2589H) DUNTK5755WEV5 (SV-2889H) SIDE PIN UNIT					MISCELLANEOUS PARTS				
INTEGRATED CIRCUIT						QJAKJ0033CEZZ	J	Headphone Jack	AE
IC1601	VHi UPC358C / - 1	J		AD	DUNTK6342WEV0 S-VIDEO TERMINAL UNIT				
TRANSISTOR					TRANSISTORS				
Q1601	VS2SD1913S / 1E	J	2SD1913S	AD	Q2300, 2301	VS2SC1815GW- 1	J	2SC1815(GW)	AB
CONTROLS					DIODE				
R1615, 1617	RVR- M4077CEZZ	J	4.7K(B) H-Size, H-Center	AB	D2300	RH- DX0045BMZZ	S	1N414N	AA

REF. NO.	PART NO.	*	DESCRIPTION	CODE	REF. NO.	PART NO.	*	DESCRIPTION	CODE
MISCELLANEOUS PARTS					CAPACITORS				
	QJAKE0054CEZZ	J	Jack, Left	AC	C3029,	VCEAAA1CW107M	J	100 16V Electrolytic	AB
	QJAKE0055CEZZ	J	Jack, Right	AC	3031				
	QS6CD0405CEZZ	J	Socket, S-VIDEO	AF	C3049	VCE9AA1HW335M	J	3.3 50V Electrolytic (N.P.)	AE
DUNTK6343WEVO TEXT UNIT					DUNTK6344WEVO IF/S-MPX UNIT				
INTEGRATED CIRCUITS					INTEGRATED CIRCUITS				
IC3001	RH-i X0975CEZZ	J		AY	IC1200	RH-i X1286CEZZ	J		AN
IC3002	RH-i X1156CEZZ	J		BE	IC1201,	VHi TA7348P/ - 1	J		AK
IC3003	RH-i X1263CEZZ	J		AT	1202				
IC3004	VHi TC4001BP- 1	J		AF					
IC3005	VHi TC4006BP- 1	J		AQ					
IC3006	VHi TC4011BP- 1	J		AF					
IC3007	RH-i X1154CEZZ	J		AW					
IC3008	RH-i X1167CEZZ	J		AP					
IC3009	VHi PST529C2- 1	J		AD					
IC3010	RH-i X1155CEZZ	J		AR					
TRANSISTORS					TRANSISTORS				
Q3001	VS2SC1815GW- 1	J	2SC1815(GW)	AB	Q1200,	VS2SC1906/ / 1E	J	2SC1906	AC
3004,					1201				
3007,					Q1202,	VS2SC1815GW- 1	J	2SC1815(GW)	AB
3009,					1203,				
3010					1205,				
					1206,				
					1207				
					Q1204	VS2SA1015Y/ 1E	J	2SA1015(Y)	AC
DIODES					DIODES				
D3001,	RH- DX0045BMZZ	S		AA	D1200	RH- EX0440CEZZ	J	Zener Diode	AA
3002,					D1201,	RH- DX0045BMZZ	S		AA
3003,					1202,				
3010,					1206				
3011,									
3012									
PACKAGED CIRCUITS					COILS				
X3001	RCRSB0099BMZZ	S	Crystal 13.875MHz	AM	L1201	VP- XF120K0000	J		AB
X3002	RCRSB0100BMZZ	S	Crystal 6.0MHz	AL	L1202,	VP- DF560K0000	J		AB
X3003	RFi LA0042CEZZ	J	Crystal 6.0MHz	AD	1204,				
					1206				
COILS					CERAMIC FILTERS				
L3001	VP- DF150K0000	J	15 μ H	AB	CF1202	RFi LC0023CEZZ	J		AE
L3002	VP- DF120K0000	J	12 μ H	AB	CF1203	RFi LC0084CEZZ	J		AF
L3003	VP- DF1R5M0000	J	1.5 μ H	AB	SF1200	RFi LC0191CEZZ	J		AH
L3004	VP- CU1R5M0000	J	1.5 μ H	AB	SF1201	RFi LC0192CEZZ	J		AH
CERAMIC FILTER					TRANSFORMERS				
CF3001	RFi LC0038GEZZ	J	800kHz	AE	T1203	RCi Li 0431CEZZ	J		AD
					T1204	RCi LD0190CEZZ	J		AD
					T1205	RCi LD0151CEZZ	J		AD
					T1206	RCi LD0192CEZZ	J		AD
CONTROL					CONTROLS				
R3066	RVR- M4077CEZZ	J	4.7K(B) Text Level	AB	R1219	RVR- M4076CEZZ	J	3.3K(B) RF AGC	AB
					R1241	RVR- M4163GEZZ	J	4.7K(B) Sub-Sound	AB

REF. NO.	PART NO.	*	DESCRIPTION	CODE	REF. NO.	PART NO.	*	DESCRIPTION	CODE
CAPACITORS					CERAMIC FILTERS				
C1209, 1211, 1223, 1233	VCEAAA1CW107M		100 16V Electrolytic	AB	CF5000 CF5001	RFi LA0044CEZZ RFi LA0043CEZZ	J J		AD AE
RESISTOR					TRANSFORMER				
R1240	RR- XZ0035TAZZ	J	22 1/4W Fuse Resistor	AB	T5000	RFi LC0194CEZZ	J		AM
DUNTK6345WEVO TEXT UNIT					CAPACITORS				
INTEGRATED CIRCUITS					C5001, 5071 C5073	VCEAAA0JW107M VCEAAA0JW227M	J J	100 6.3V Electrolytic 220 6.3V Electrolytic	AB AB
IC5000 IC5001 IC5002 IC5003 IC5004 IC5005 IC5006, 5010 IC5007, 5008 IC5009	RH- i X1184BMZZ RH- i X1262CEZZ VHi PST529C2- 1 VHi TA8662N/ - 1 VHi TC6011N/ - 1 VHi M5165P10- 1 VHi UPC358C/ - 1 RH- i Z0076CEZZ VHi TD6710AN- 1	S J J J J J J J J		AG AR AD AZ BD AV AD AS AT	TRIMMER				
TRANSISTORS					C5022 C5039	RT5- H0010TAZZ RT5- H1048GEZZ	J J	50p 20p	AE AC
DIODES					MISCELLANEOUS PARTS				
Q5000, 5001 Q5002 Q5003	VS2SA1015G/ 1E VS2SC2236Y/ - 1 VS2SC1815GW- 1	J J J	2SA1015(GW) 2SC2236 2SC1815(GW)	AC AD AB	Δ	QACCB9011CEZZ VSP0080PBE1WA VSP1608PB068A RRMCG0640CESA	J S S J	AC Cord Speaker (SV-2189H) Speaker (SV-2589H/2889H) Infrared Remote Control Unit	AN AW AY BA
PACKAGED CIRCUITS					COILS				
D5000, 5001, 5002 D5003	RH- DX0045BMZZ RH- EX0159GEZZ	S J	1N4148 Zener Diode	AA AA	L5000, 5007 L5001, 5002, 5004, 5008 L5003 L5005, 5006	VP- DF3R3K0000 VP- DF150K0000 VP- MK8R2K0000 VP- MK681K0000	J J J J	3.3μF 15μF 8.2μF 680μF	AB AB AB AB
X5000 X5001	RCRSB0131CEZZ RCRSB0132CEZZ	J J	Crystal—6.552MHz Crystal—5.824MHz	AH AH	TLABH1068CEZZ				

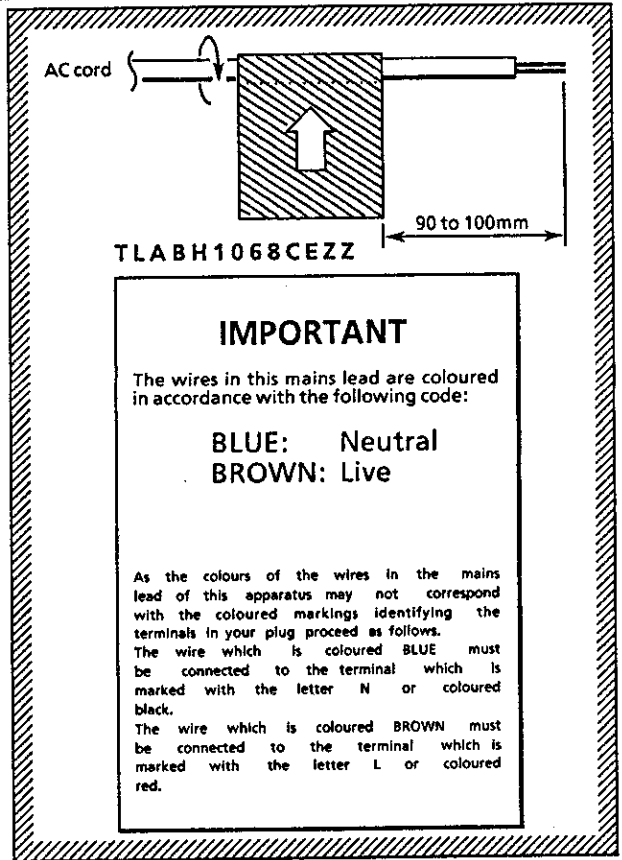

REF. NO.	PART NO.	*	DESCRIPTION	CODE	REF. NO.	PART NO.	*	DESCRIPTION	CODE
MODELS SV-2189H SV-2589H SV-2889H CABINET PARTS					1-5	HPNC- 0229BMSA	S	Perforated Panel (Left) (SV-2889H)	AU
					1-6	GDöRF 1767BMSA	S	Front Door (SV-2189H)	AR
					1-6	GDöRF 1768BMSA	S	Front Door (SV-2589H/2889H)	AT
1	CCABA1782WEV5	S	Front Cabinet Ass'y (SV-2189H)	BP	1-7	GMADT0275BMSA	S	Window	AD
	CCABA1743WEW1	S	Front Cabinet Ass'y (SV-2589H)	BR	1-8	HBDGS3119BMSA	S	Badge	AC
	CCABA1744WEV9	S	Front Cabinet Ass'y (SV-2889H)	BS	1-9	Hi NDP 3365BMSA	S	Indication Plate (SV-2189H)	AK
1-1	Not Available	—	Front Cabinet	—	1-9	Hi NDP 3368BMSA	S	Indication Plate (SV-2589H/2889H)	AK
1-1	Not Available	—	Speaker Panel (Right)	—	1-10	Hi NDP 3366BMSA	S	Indication Plate (LED)	AG
1-2	Not Available	—	Speaker Panel (Left)	—	2	CCABB1827WEV4	S	Rear Cabinet Ass'y (SV-2189H)	BL
1-3	Not Available	—	Speaker Panel (Left)	—	2	CCABB1785WEV1	S	Rear Cabinet Ass'y (SV-2589H)	BN
1-4	HPNC- 0230BMSA	S	Perforated Panel (Right) (SV-2189H)	AT	2	CCABB1786WEV1	S	Rear Cabinet Ass'y (SV-2889H)	BP
1-4	HPNC- 0214BMSA	S	Perforated Panel (Right) (SV-2589H)	AT	2-1	Not Available	—	Rear Cabinet	—
1-4	HPNC- 0216BMSA	S	Perforated Panel (Right) (SV-2889H)	AT	2-2	Hi NDP 3268BMSA	S	Rear Indication Plate	AP
1-5	HPNC- 0232BMSA	S	Perforated Panel (Left) (SV-2189H)	AT	2-3	JBTN- 1574BMSA	S	Button, Power (Rear)	AC
1-5	HPNC- 0228BMSA	S	Perforated Panel (Left) (SV-2589H)	AT					

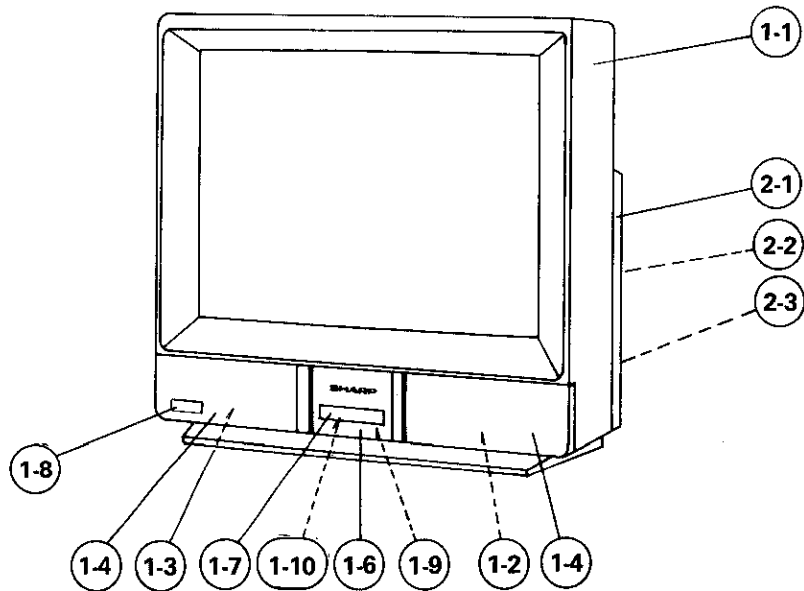

PACKING OF THE SET

MODEL SV-2189H

Guarantee card (Set)
 TGAN-1190BMZZ
 Instruct
 TINS-4057BMZZ
 G-Instruct
 TINS-4257BMZZ
 Guarantee card (CRT)
 TGAN-1245BMZZ

Infrared remote control unit

Batteries

Dustproof cover
 SPAKP0521BMZZ

Buffer material
 SPAKX1994BMZZ

MODELS SV-2589H and SV-2889H

Guarantee card (Set)
 TGAN-1190BMZZ
 Instruct
 TINS-4057BMZZ
 G-Instruct
 TINS-4257BMZZ
 Guarantee card (CRT)
 TGAN-1245BMZZ

Infrared remote control unit

Batteries

Dustproof cover
 SPAKP0532BMZZ (SV-2589H)
 SPAKP0533BMZZ (SV-2889H)

Buffer material
 SPAKX1963BMZZ (SV-2589H)
 SPAKX1967BMZZ (SV-2889H)

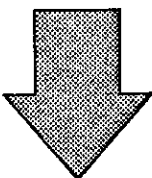

Packing case
 SPAKC3786BMZZ (SV-2189H)
 SPAKC3817BMZZ (SV-2589H)
 SPAKC3787BMZZ (SV-2889H)

FRONT

Use 24 staples to fix the packing case.

Serial number label

Number card

